

Technical information for indexing plunger 03096-42

1. Application:

Form A (without center position)

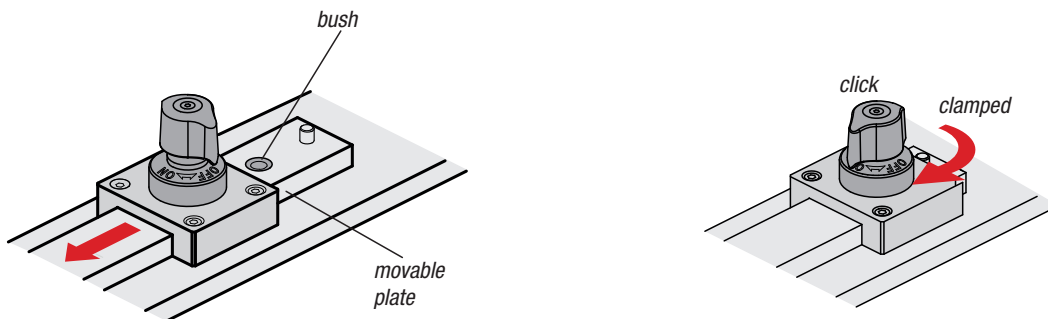

Check that the twist knob is in the “OFF” position and that the pin is retracted.

Slide the plate with the bushing under the indexing plunger.

To clamp, turn the twist knob to the “ON” position.

When fully clamped, a click sound is heard.

Caution: Do not loosen the clamping of the indexing plunger when the pin is under an axial load. Due to the conical shape, the pin may not retract.

Form B (with center position)

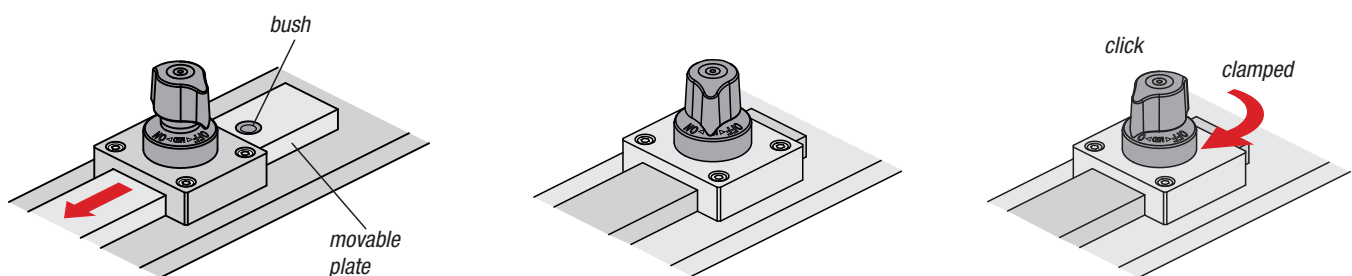

With the twist knob in the “OFF” position, slide the plate with the bushing towards the indexing plunger until the spring locks the pin into the bush.

The twist knob will move automatically to the “MID” position.

For complete clamping, turn the twist knob from the “MID” position to the “ON” position until a click signal is heard.

Technical information for indexing plunger 03096-42

2. Function:

Style A (without center position)

twist knob in OFF position

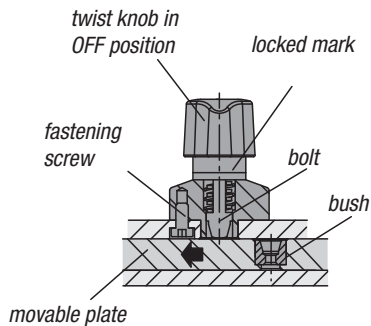

The pin remains retracted when the knob is released. The locked mark (red) is visible and the plate can be moved. Move the plate to the correct position.

twist knob in ON position

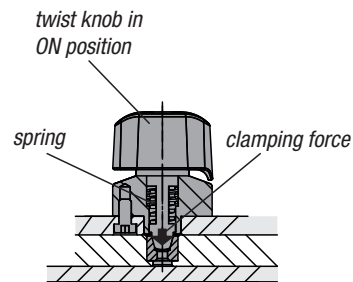

When the knob is turned to the "ON" position, the pin and the bushing are pressed together by a powerful spring and clamped, a clamping force is created.

Style B (with center position)

twist knob in OFF position

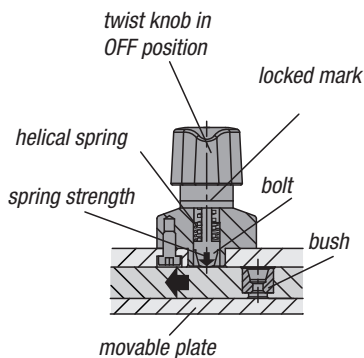

When the knob is released, the pin moves into the MID position and presses against the moveable plate under light spring pressure. The helical spring takes up the forces within the body. The locked mark (red) is visible and the plate can be moved.

twist knob in MID position

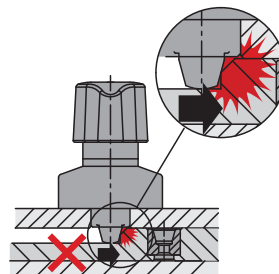

In the MID position, the pin does not retract upon contact with a protrusion, there is a risk of collision.

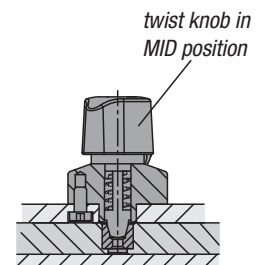

When the plate is moved to the correct position, the pin locks automatically under spring pressure. When the knob is turned to the "ON" position, the pin and the bushing are pressed together by a powerful spring and clamped, a clamping force is created.

Technical information for indexing plunger 03096-42

3. Technical Information

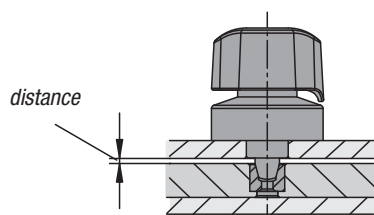

Recommended spacing between the plates: 0.2 mm or less

Application examples:

Fixating and clamping slide plates

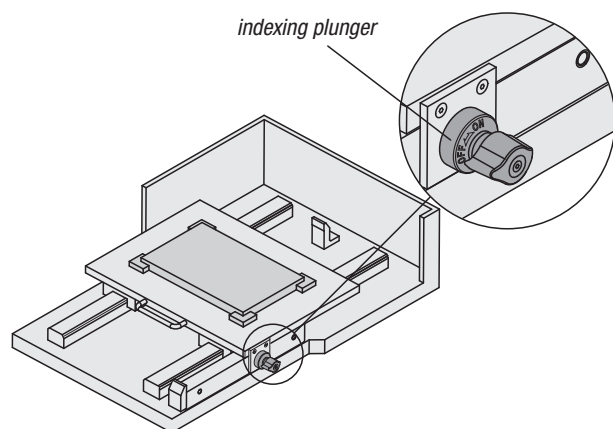

Fixating and clamping rotary units

